



TwinSource

DCC - II RMSTS

Rack Mount Static Transfer Switch

Introducing the new TwinSource Dual Cord Converter DCC-II-RMSTS static transfer switches for critical IT applications. This family of plug-in rack-mount IT static transfer switches (RMSTS) utilizes the latest state-of-the-art, fault tolerant, patent pending logic topology which provides higher redundancy of critical components than other STS designs, with a first time ever predicted MTBF of over 50 million hours. This super high reliability and internal redundancy makes the DCC-II the number one choice to meet the ultra-high availability requirements of mission critical IT operations at critical data centers, air traffic control sites, and telecommunications centers demanding 7x24 availability. They are ideal to convert single corded IT loads to dual corded configuration so as to achieve the same availability as the dual corded loads.



The DCC-II RMSTS uses a Power Quality Seeking sense circuit that enables the critical load to always be on the better of the two sources. The system does this through the use of a unique triple band power quality discriminator circuit that categorizes the voltage at each source into: Good Quality, Marginal Quality, and Unacceptable Quality voltage bands. The system always seeks the Good Power Quality band and the bands are user settable. This unique and advanced failure avoidance feature enables the RMSTS to keep the load in a safe zone of power quality unlike switching devices that stay on the edge of power failure before initiating a transfer at high risk. The built-in bypassing and isolation outer module, combined with the inner plug-in electronics module, give the TwinSource DCC-II RMSTS the lowest MTTR (Mean Time To Repair) in the industry of less than 2 minutes. The comprehensive user adjustable settings for power quality allow the user full customization capability to match the specific load requirements to the facility power. The RMSTS also comes with an optional RS-485 Modbus user interface that can be connected to a BMS system for monitoring of status and alarms or at a much lower cost, to a TwinSource provided ETU (Ethernet Translator Unit) that would enable conversion of the very same data to LAN/Web readable color-graphic displays with time stamped event archiving capabilities that can be downloaded when desired. As many as 16 ETUs can be monitored from the same PC and each ETU can monitor up to 16 x RMSTSs. Alarm Acknowledge and Preferred Source Selection commands can be performed by the user from the monitoring PC.

This product is certified to UL1008 Standard and is CE labeled and is available in all worldwide voltages and frequencies making it ideal for multinational operations worldwide.

Standard Features

- Two Pole Device (avoids ground circulating currents)
- Calculated MTBF > 1 million hours
- Predicted MTBF > 50 million hours
- Lowest MTTR < 2 minutes
- Plug-in "hot swappable" electronic module
- Certified to meet UL-1008, CE Labeled
- Self Diagnostic Scanning - identifies all causes of alarms immediately - eliminates troubleshooting by a technician
- Redundant logic power supplies
- Redundant fans
- User selectable settings
- "Auto-retransfer Off" protection
- Anti-cross connection logic
- Power Quality Seeking System
- Shorted/Open SCR protection
- Short Circuit: 22KA
- Internal Maintenance Bypass (with programmed pre-transfer alarm to avoid operator error)
- Operator "Do Not Bypass" alarm to help operator

Applications

Critical Data Centers
Telecommunications Sites
Air Traffic Control Sites
Petrochemical Plants
Semiconductor Fab Plants Controls
Critical Industrial Controls

Options

- RS-485 (Modbus RTU)
- Ethernet LAN Interface
- Interlocks to prevent withdrawing the electronic module
- 2X30A output distributions to feed 2 separate cords or racks from a single switch

Front View

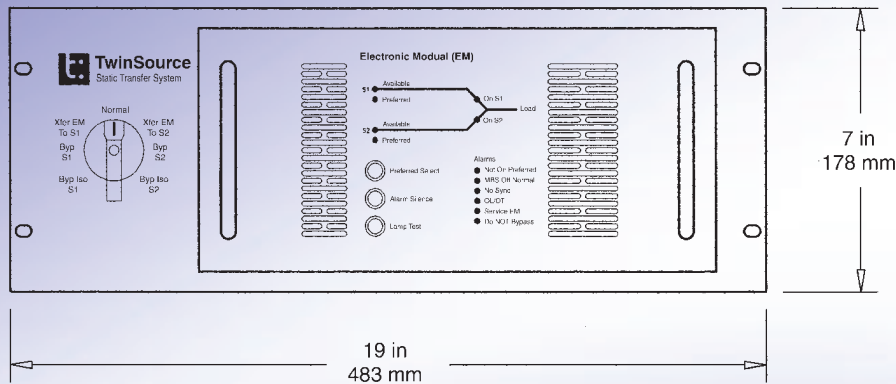

RMSTS Schematic

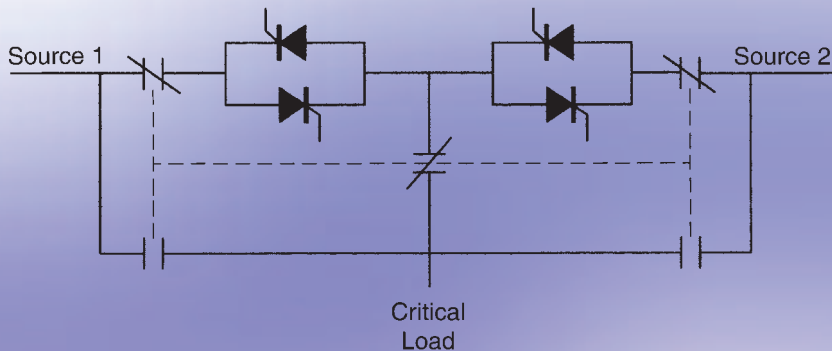

Basic Specifications

Electrical Characteristics

Current Rating	30, 40, 50 A
Voltage	120, 208, 220, 230, 240V
	1-ph, 50 and 60Hz
Poles	2

Operational Characteristics

Sense and transfer time
1/4 cycle

User Adjustable Settings

- Over and Under Voltage
- Phase Angle for Manual Transfer
- Default Preferred
- Unit Address for ETU
- Auto-retransfer On/Off

Panel Controls

- Preferred Select
- Alarm Silence
- Lamp Test
- Bypass Isolation Selector Switch
- Diagnostics (selftest)

Remote Contacts

- Service EM
- Summary Alarm

Panel Indicators

- Source 1 Available
- Source 2 Available
- Source 1 Preferred
- Source 2 Preferred
- On Source 1
- On Source 2

Alarms

- Not On Preferred
- MBS Off Normal
- No Sync
- OL/OT
- Service EM
- Do Not Bypass

Environmental Specifications

Operating Temperature	
Range	0°C to 40°C
Relative Humidity	0% to 95% noncondensing

Physical Specifications

Weight	49 lbs/23 kg
Dimensions	H - 7 in/178 mm
	W - 19 in/483 mm
	D - 21 in/526 mm

TwinSource LLC with corporate offices in the US and UK is a worldwide leading supplier of single-phase, rack mount RMSTS transfer switches for a variety of applications. Our Dual Cord Converter II (DCC-II) solid state 1/4 cycle RMSTS product, is ideal for protecting super-critical IT operations or transactions, where speed of transfer and ultra fault-tolerant reliability are pre-requisite requirements of transaction missions that can cost millions if disrupted.

TwinSource also supplies an electromechanical product our MagLatch RMATS in 30A rating and for all voltages and frequencies worldwide. This product uses the same reliable and fast acting TwinSource sense and control logic that control the main dual coiled magnetically latched transfer relays for superior performance.

TwinSource has high level expertise in electrical and electronics engineering onboard for developing its state of the art fault tolerant transfer mechanisms utilizing patent pending technology owned by the company. TwinSource product lines are well known for their high reliability, excellent workmanship, ease of use, lowest MTTR, and have set a new standard for rack-mount transfer switches in the industry.



TwinSource, LLC, USA

32333 Aurora Road
Solon, Ohio, 44139, USA
Phone: (440) 248-6800
Fax: (440) 349-2678
Web: www.twinsource.net



TwinSource Ltd, UK

78 Kenyon Street,
London SW6 6LB, UK
Phone: +44(0) 20 7610 3770
Fax: +44(0) 20 7386 8715
Web: www.twinsource.net